

A 300

AIRPLANE CHARACTERISTICS

Printed in France

AA 5 02 02 00 0 AA 0

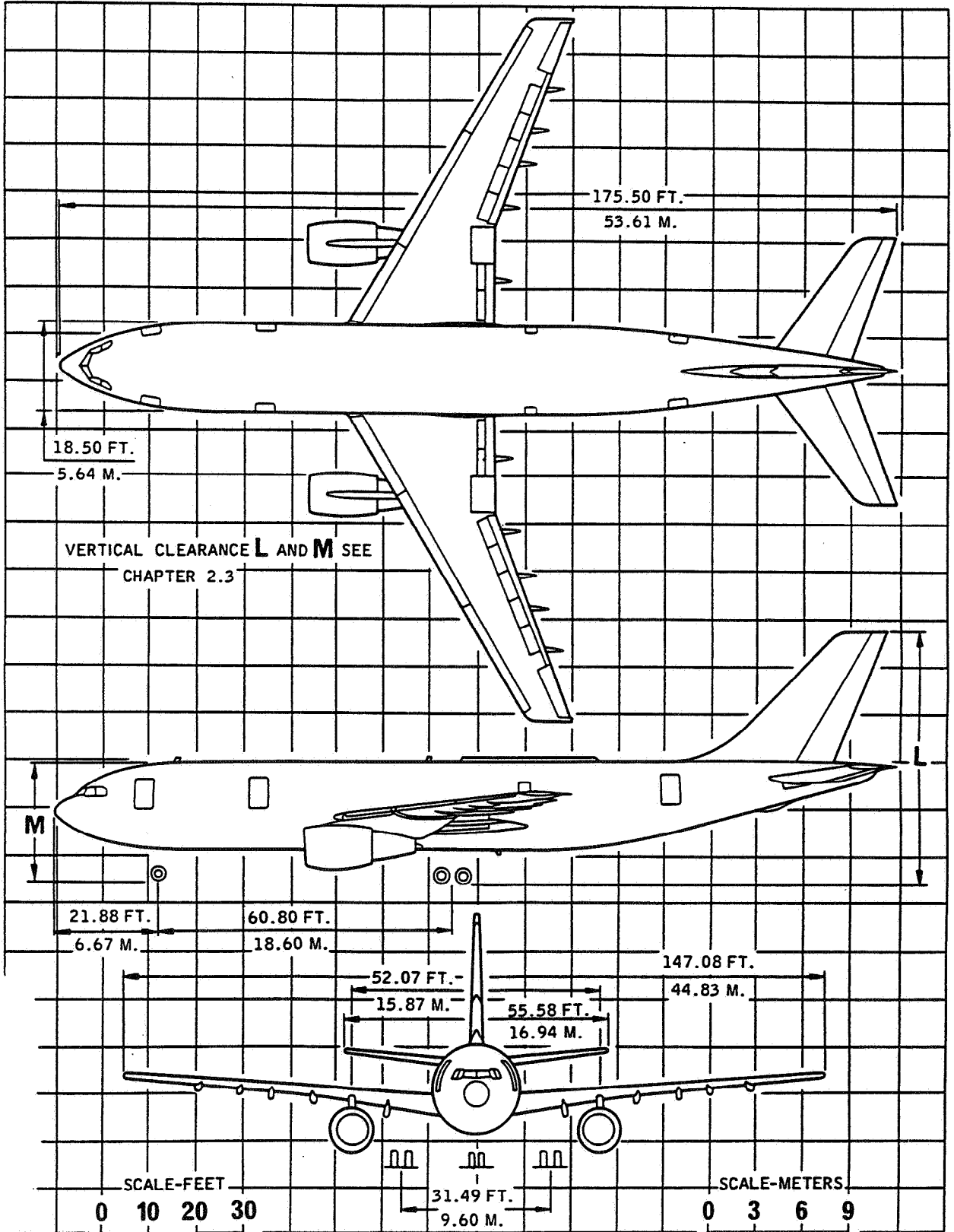

2.2 GENERAL DIMENSIONS
MODEL B2 - B4

A 300
AIRPLANE CHARACTERISTICS

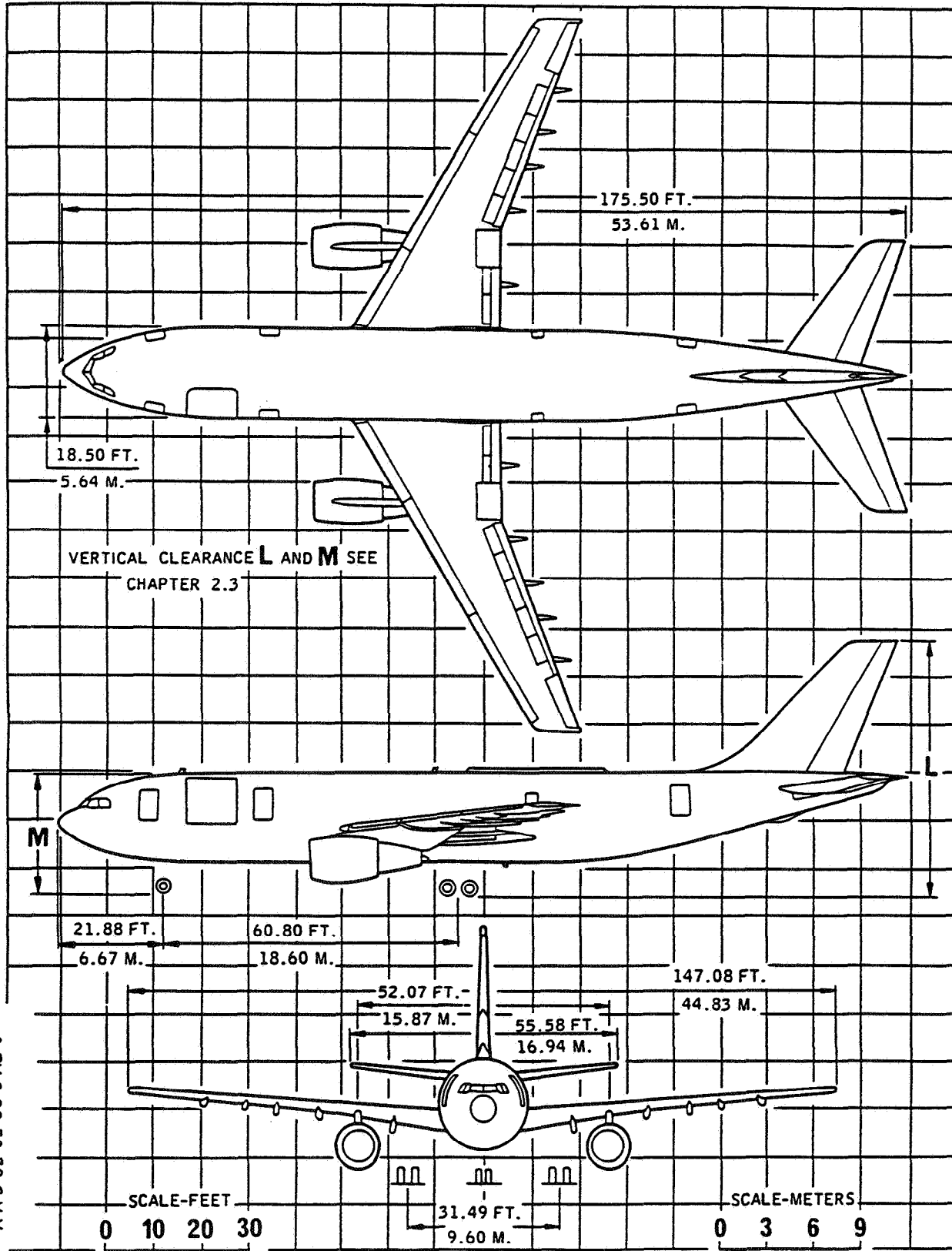

Printed in France

A A 5 02 02 00 0 AB 0

2.2 GENERAL DIMENSIONS
MODEL C4

A 300

AIRPLANE CHARACTERISTICS

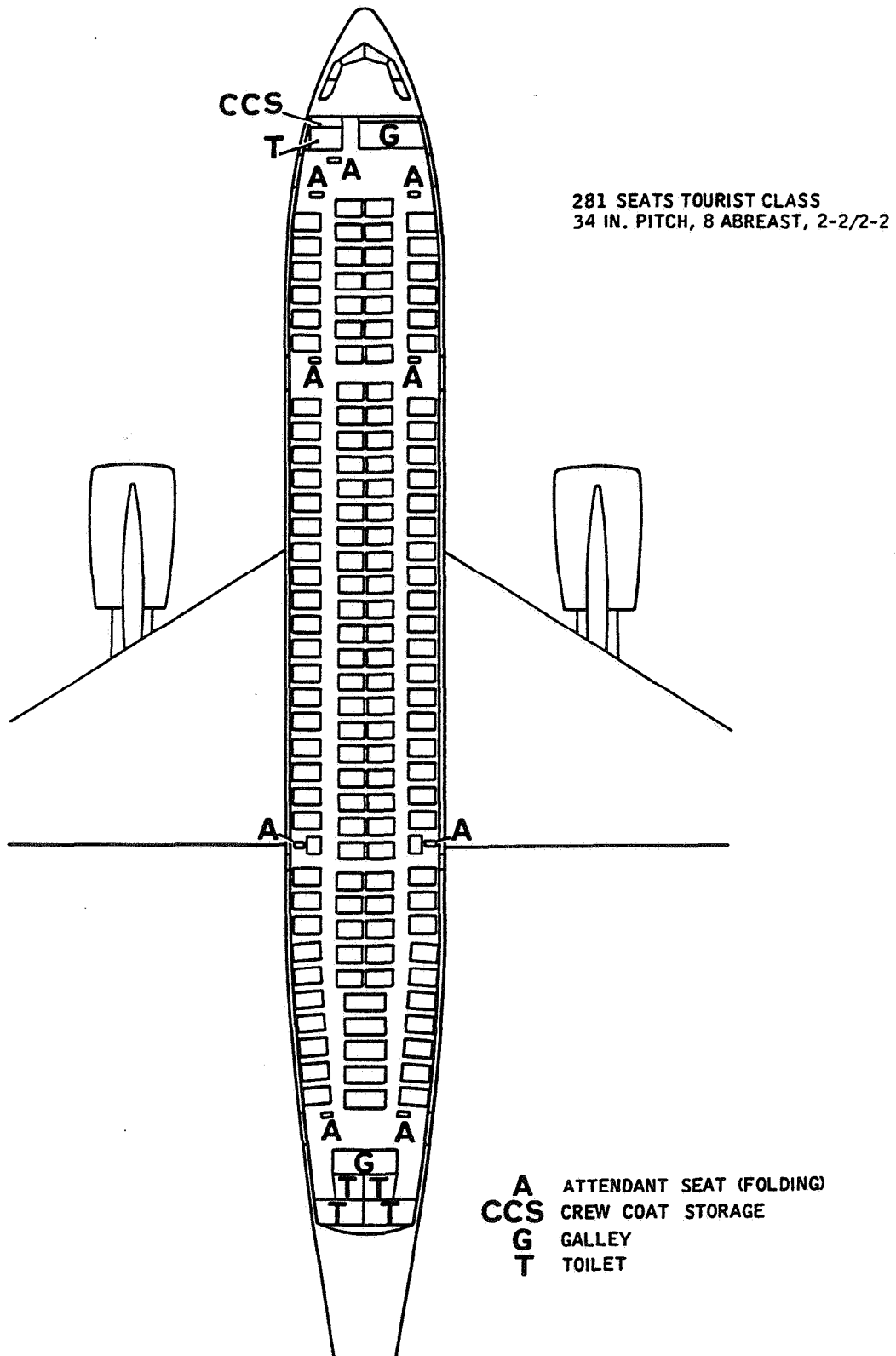

Printed in France

A A 5 02 04 00 0 AF 0

2.4 INTERIOR ARRANGEMENT
2.4.1 BASIC VERSION
MODEL B2 - B4 - C4

A 300

AIRPLANE CHARACTERISTICS

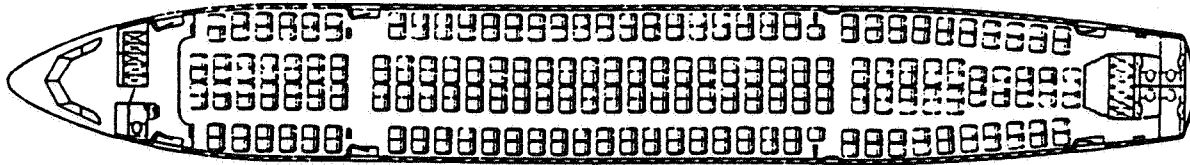

281 seats

A variety of seating configuration is possible without modifications to the seat rails or floor support structure.

The aircraft is certificated for the carriage of up to 345 passengers.

Printed in France

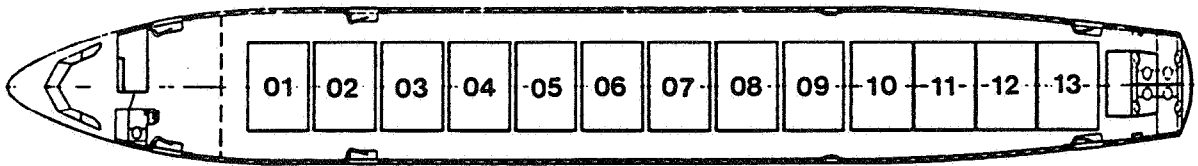

Mixed pallets
88" x 125"
96" x 125"

The above figure shows the numbering of the pallet positions in the cabin. Either 88" x 125" or 96" x 125" pallets can be loaded in any position from 01 to 09. Only 88" x 125" pallets can be loaded in position 10 to 13.

AA 5 02 04 03 0 AA 0

2.4 INTERIOR ARRANGEMENT

2.4.3 BASIC UPPER DECK CONFIGURATIONS

MODEL C4

AIRBUS  INDUSTRIE
A 300
 AIRPLANE CHARACTERISTICS

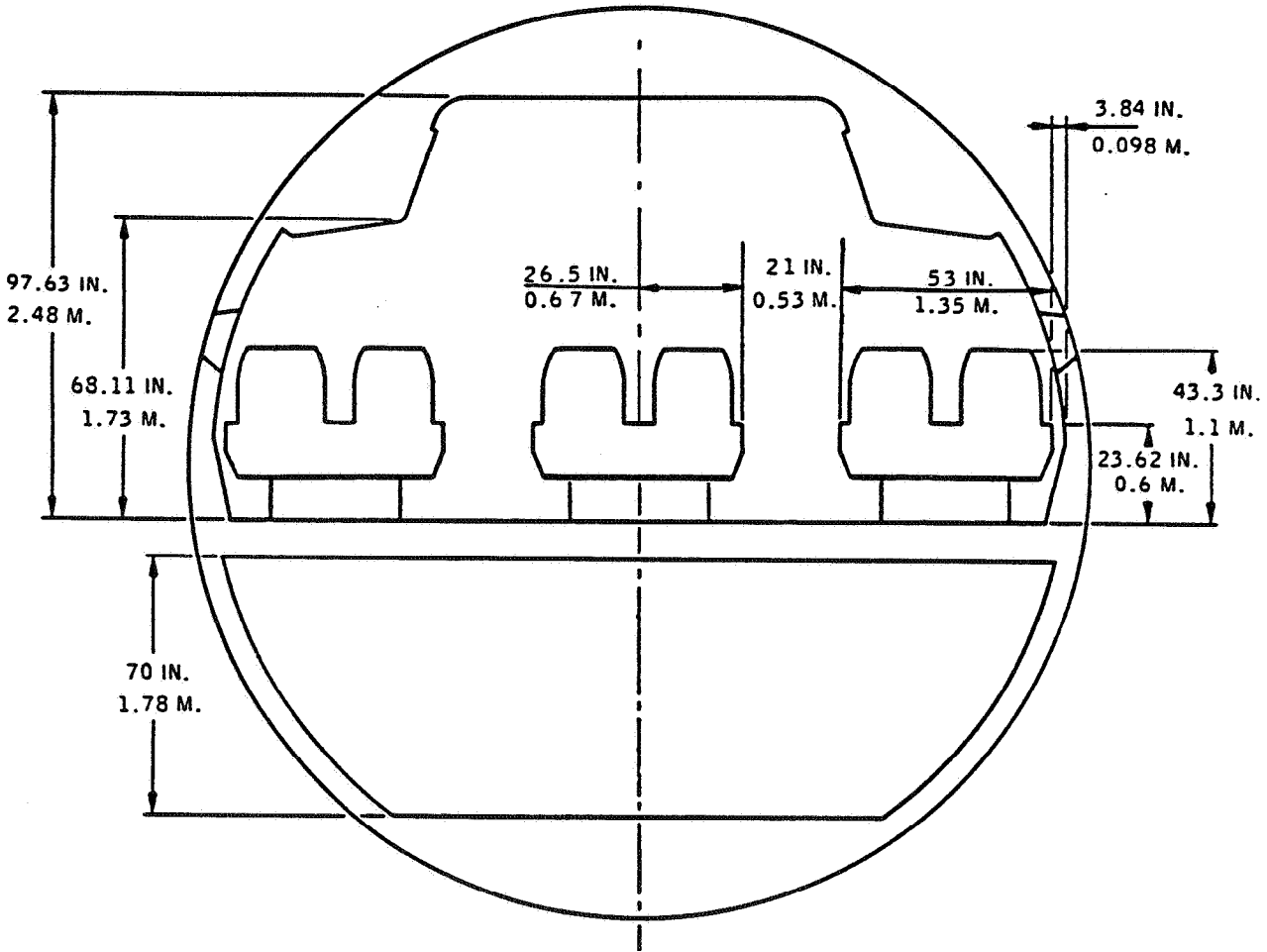

Printed in France

A A 5 02 05 01 0 AA 0

2.5 PASSENGER CABIN CROSS SECTION
 2.5.1 SEATING CONFIGURATION - 6 ABREAST - FIRST CLASS
 MODEL B2 - B4 - C4

A 300
AIRPLANE CHARACTERISTICS

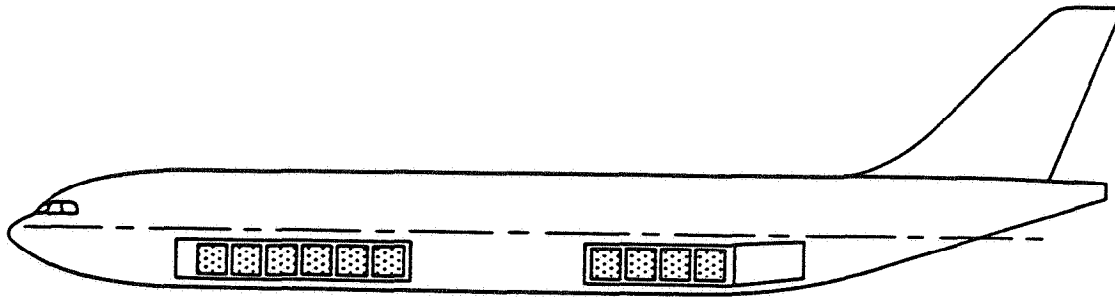

CARGO DOORS AND
BULK CARGO DOOR
R H SIDE

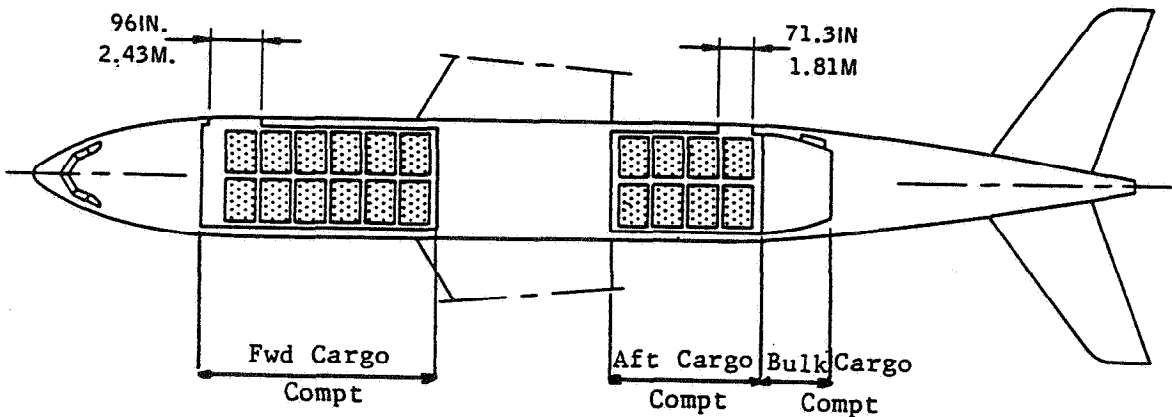

Printed in France

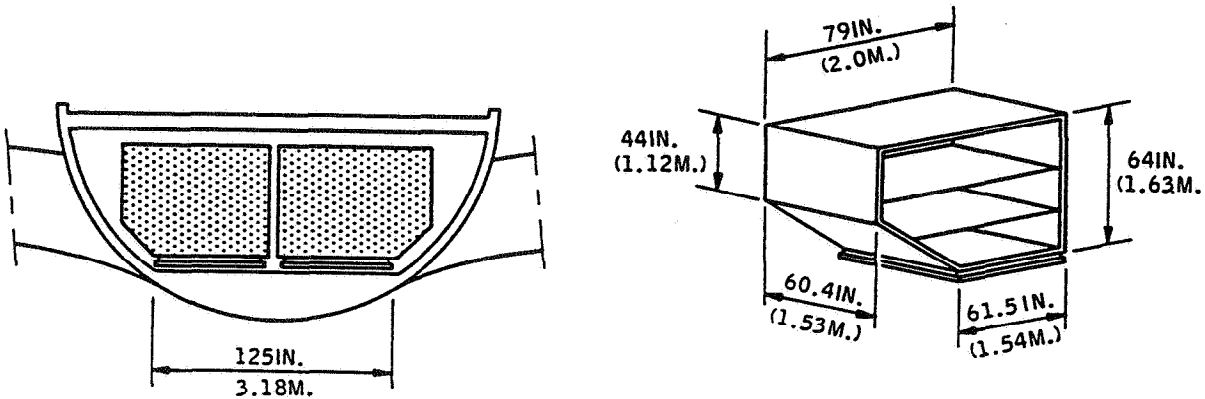

2.6 LOWER COMPARTMENTS
2.6.2 CONTAINERS
MODEL B2 - B4 - C4

A A 5 02 06 00 0 BF 0

A 300

AIRPLANE CHARACTERISTICS

Printed in France

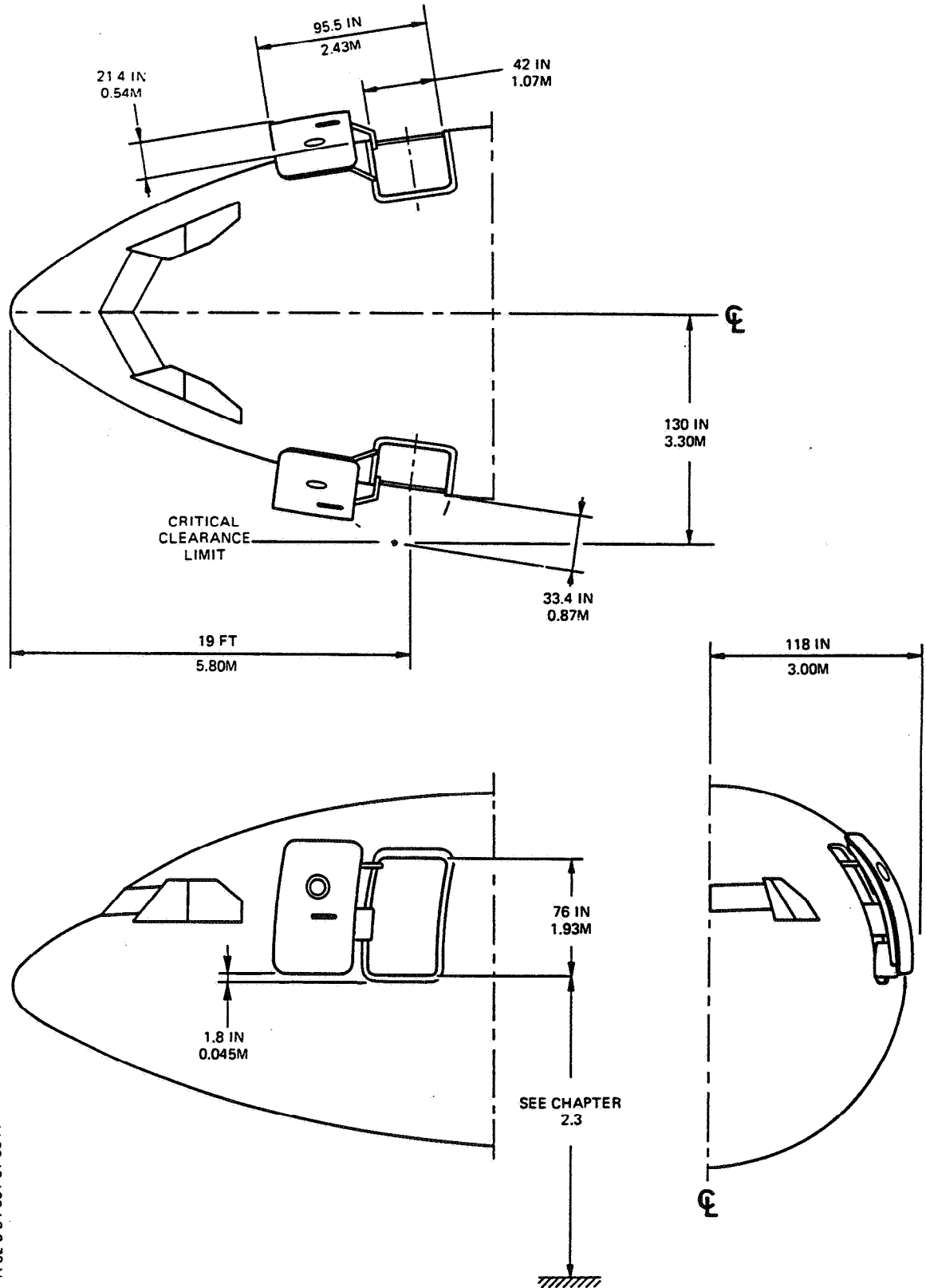

A 2301 11 000 AM 0
A 52 58 P001 01 00 A

2.8 DOOR CLEARANCES

2.8.1 FORWARD PASSENGER DOOR

MODEL B2 - B4 - C4

A 300
AIRPLANE CHARACTERISTICS

Printed in France

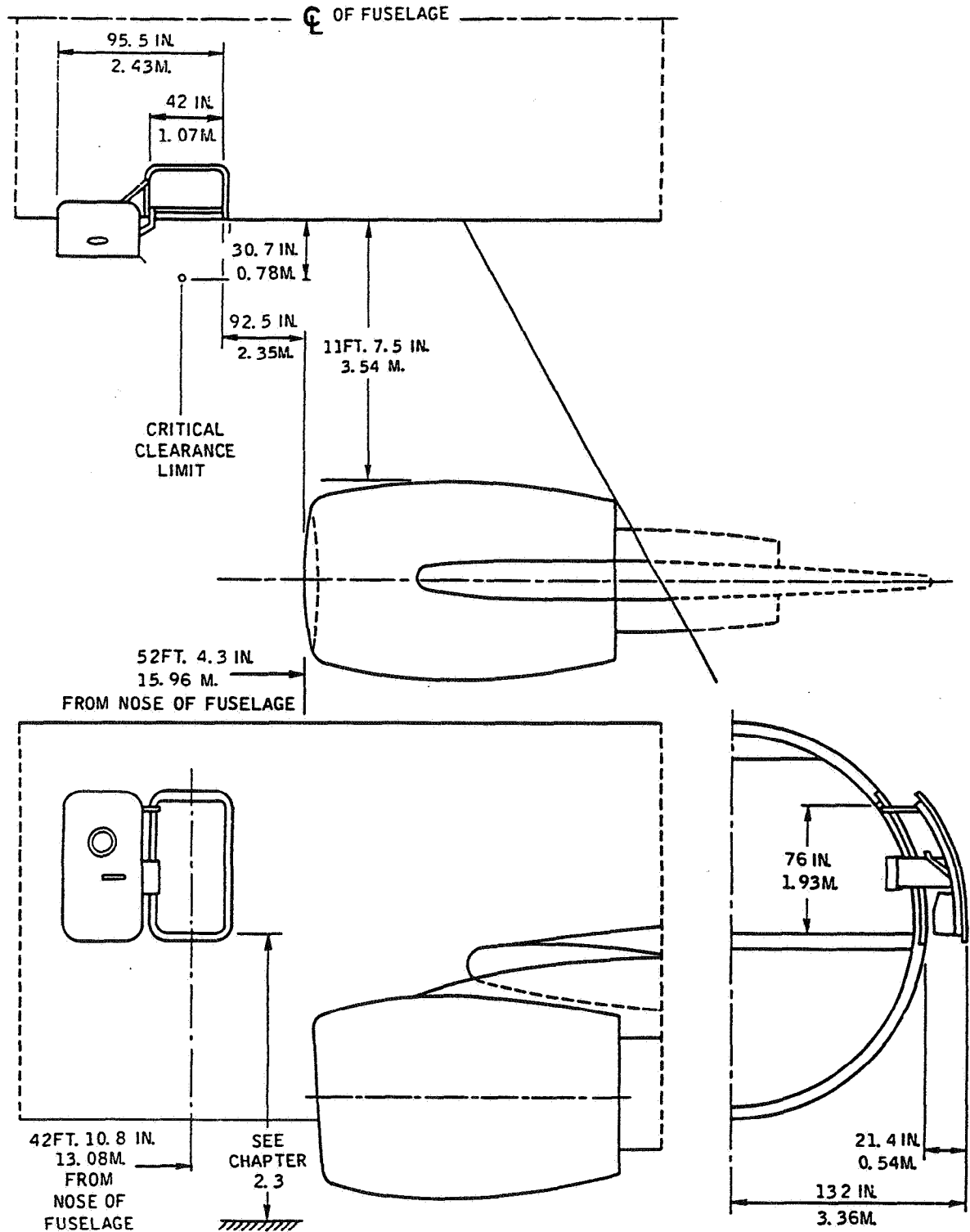

AA 5 02 08 02 0 AB 0

2.8 DOOR CLEARANCES
2.8.2 MIDDLE PASSENGER DOOR
MODEL B2 - B4 - C4 P. & W. ENGINES

A 300
AIRPLANE CHARACTERISTICS

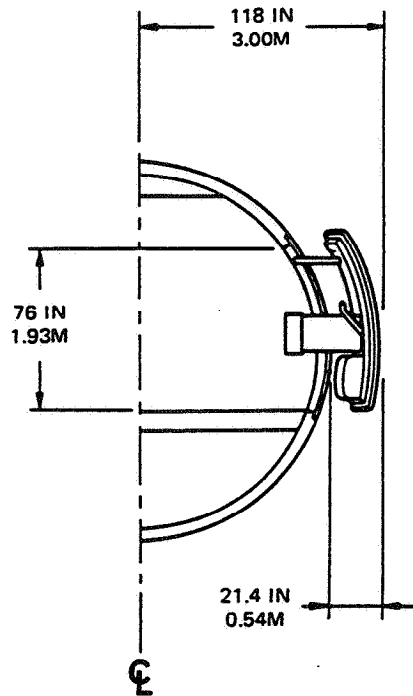
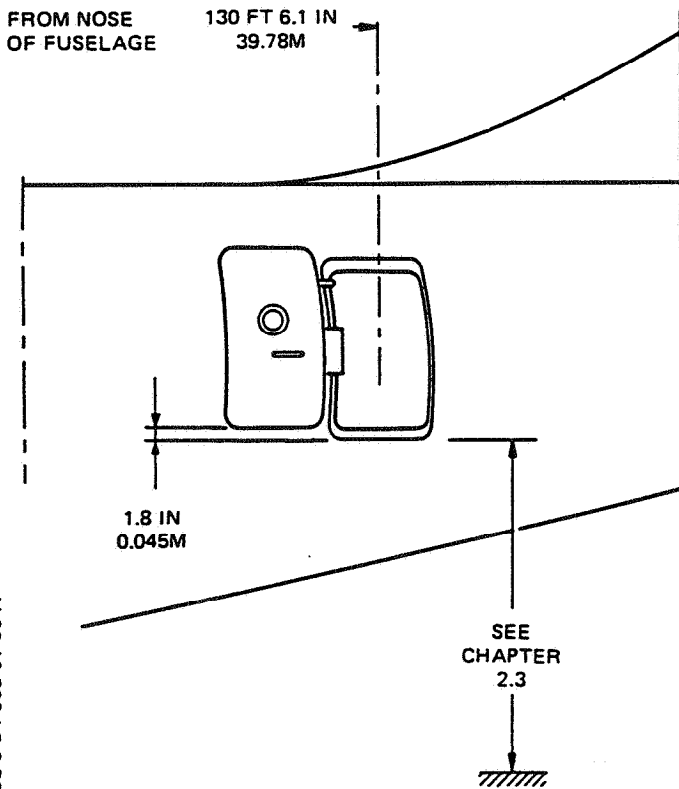
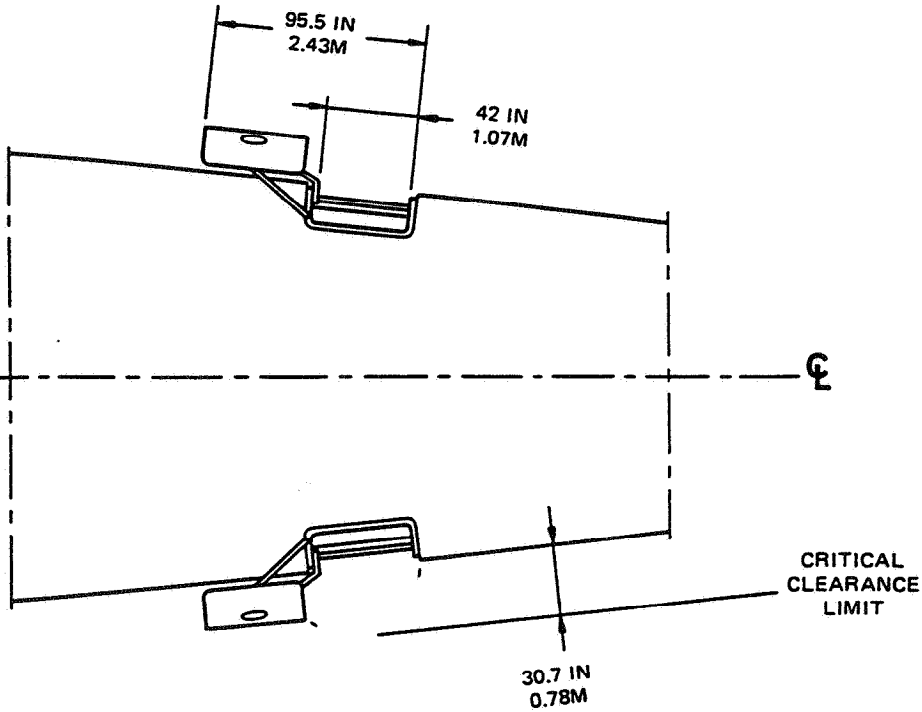

A 2301 11 000 0 CM 0
A 525 B P003 01 00 A

2.8 DOOR CLEARANCES
2.8.3 AFT PASSENGER DOOR
MODEL B2 - B4 - C4

A300
AIRPLANE CHARACTERISTICS

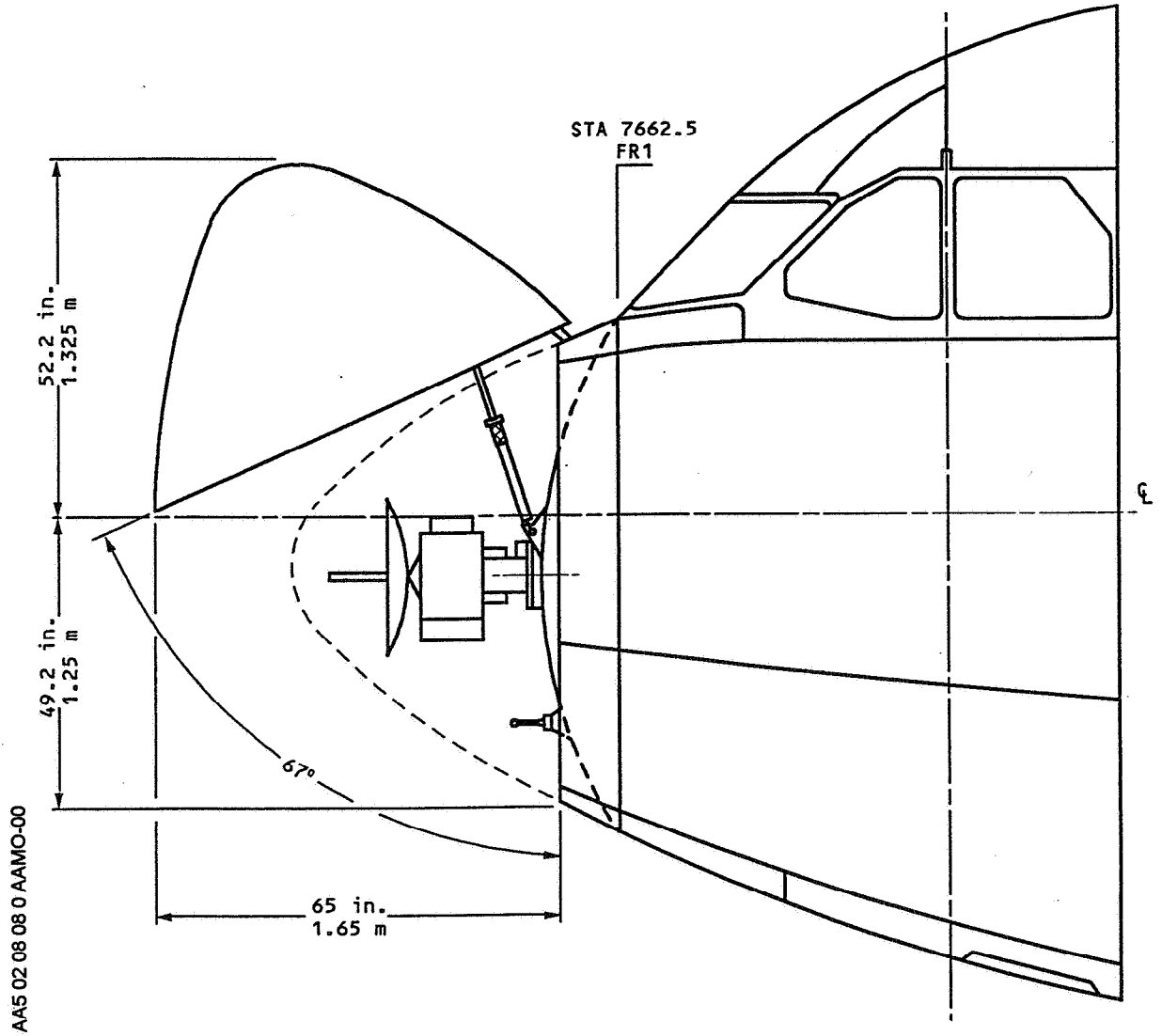

2.8 DOOR CLEARANCES
2.8.8 RADOME TRAVEL

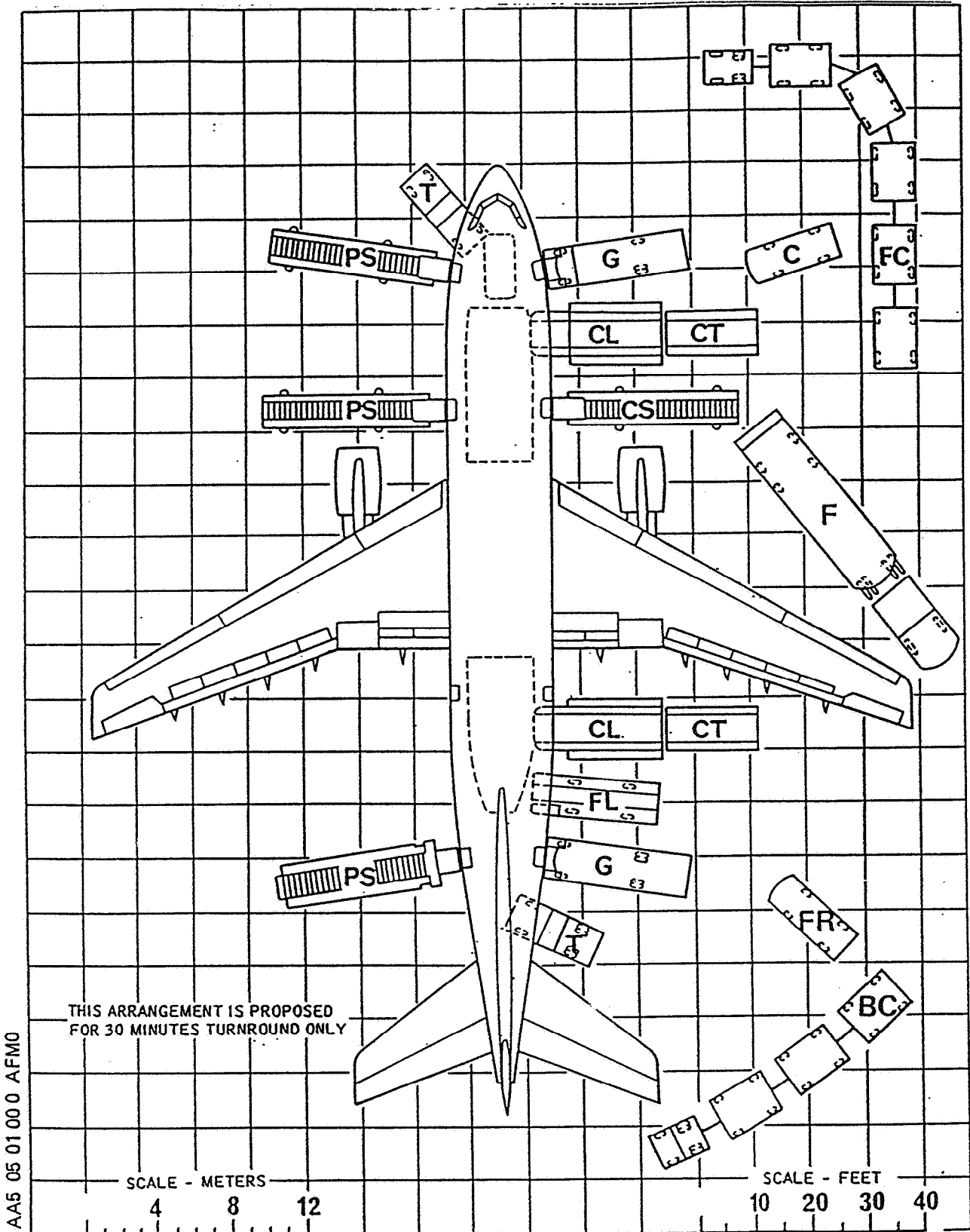

5.1 AIRPLANE SERVICING ARRANGEMENT
5.1.2 OPEN APRON FREE STANDING - APU RUNNING
MODEL B2 - B4 - C4 PASS